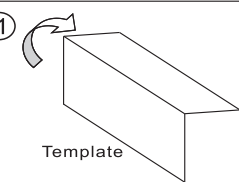
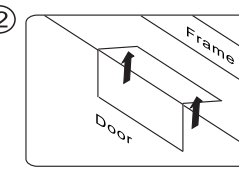

Electromagnetic Lock Installation Instruction (NH Indoor Series)

For Outswing Doors

1  Fold the mounting template 90°

Template

2  Place the template to the proper position of the door and frame. Mark the hole positions of the template on the door and frame.

Door Frame

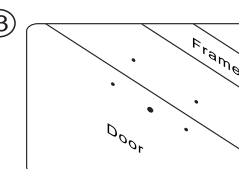
3  Drill the holes according to the marks.

Door Frame

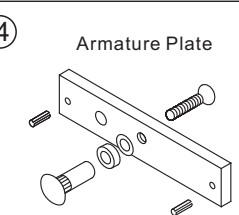
4  Armature Plate

Please install the armature plate as illustrated here. (Dimensions of the holes are depending on the door types as illustrated below.)

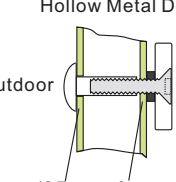
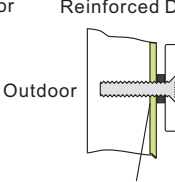
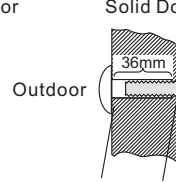
<p>Hollow Metal Door</p>  <p>Outdoor</p> <p>12.7mm 8mm</p>	<p>Reinforced Door</p>  <p>Outdoor</p> <p>6.8mm for M8-1.25 thread</p>	<p>Solid Door</p>  <p>Outdoor</p> <p>12.7mm 8mm</p> <p>36mm</p>
-----------------------------------------------------------------------------------------------------------------------------------------------	-----------------------------------------------------------------------------------------------------------------------------------------------------------	----------------------------------------------------------------------------------------------------------------------------------------------------

Drill a Ø8mm hole through door, on closing side enlarge to Ø12.7mm by a sexnut blot on the opening side.

Drill a Ø6.8mm hole and tap on closing side a M8x1.25 thread.

Drill a Ø8mm hole through door on closing side enlarge to Ø 12.7mm, by a sexnut blot on the opening side. The depth is 36mm.

Recommendation:

- For Micro EM-locks (300 LBS), maximum thickness of door is 44 mm.
- For Mini EM-locks (600 LBS), maximum thickness of door is 50 mm.
- For Midi EM-locks (800 LBS), maximum thickness of door is 48 mm.
- For Maxi EM-locks (1200 LBS), maximum thickness of door is 46 mm.

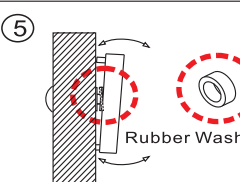
5  Rubber Washer

The rubber washer makes the surface of the armature plate adjustable in order to completely fit the surface of magnetic lock.

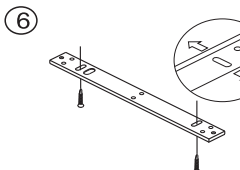
6  Fasten the mounting plate with the mounting screws. The position of the mounting plate should be adjustable.

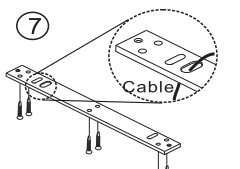
7  Cable

Fix the mounting plate on the door with mounting screws

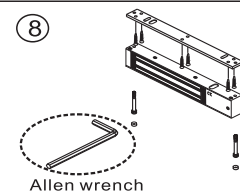
8  Allen wrench

Use the Allen wrench and fixing bolts to tighten the electromagnetic lock to mounting plate.

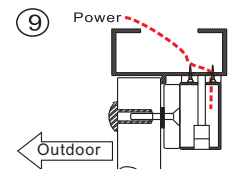
9  Power

Connect the power and test the holding force. Add washers if there is gap between the maglock and the armature plate and then tap the screw holes.

Outdoor

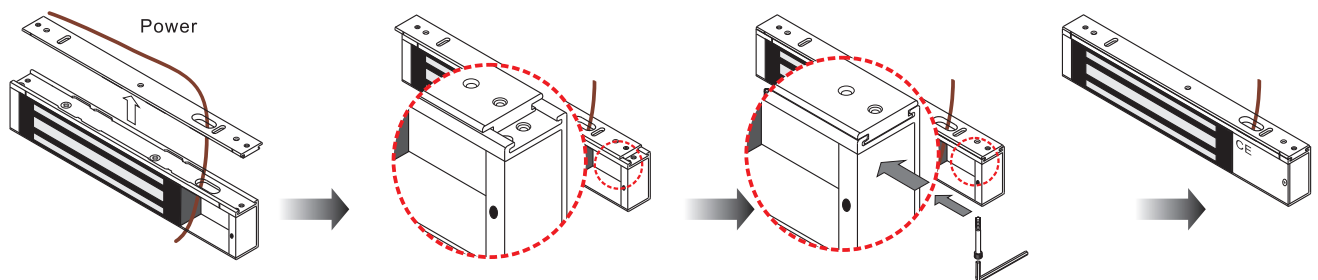

Pass the power cable through the mounting plate and the slot hole of magnetic lock.

Insert the magnetic lock into the mounting plate (Insert at 1 cm from the edge of the mounting plate.)

Slid the electromagnetic lock into the mounting plate.

Use the Allen wrench and fixing bolts to tighten the electromagnetic lock to the mounting plate.

LZ bracket for Inswing doors

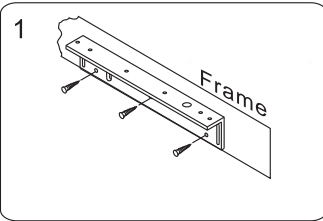

1 Find a mounting position on the door frame for the L bracket. Make sure that the door is still closeable.

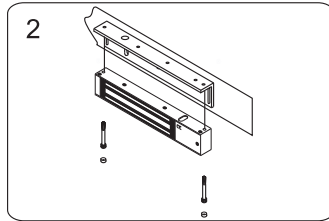

2 Use the fixing bolt to tighten the electromagnetic lock on L bracket.

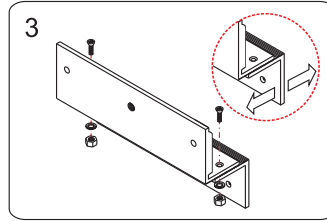

3 Assemble the Z bracket, and make sure that the position of the Z bracket is adjustable.

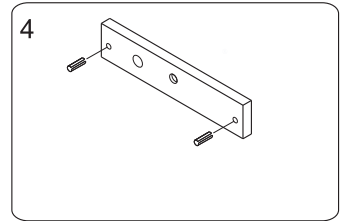

4 Insert the guide pins into the armature plate.

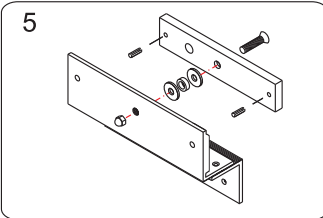

5 Fasten the armature plate to the Z bracket (Must add rubber washer)

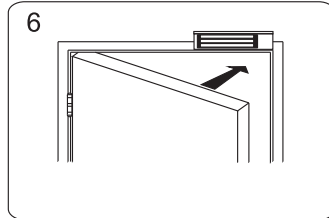

6 Close the door and connect the power

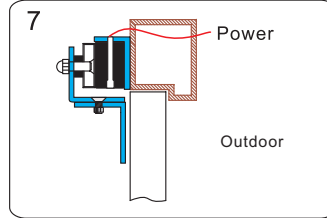

7 After the maglock attracts the armature plate, adjust the Z bracket to fit the door.

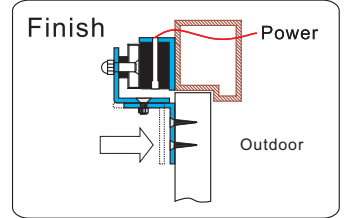

Finish Fasten the Z bracket to the door.

Connecting Diagram

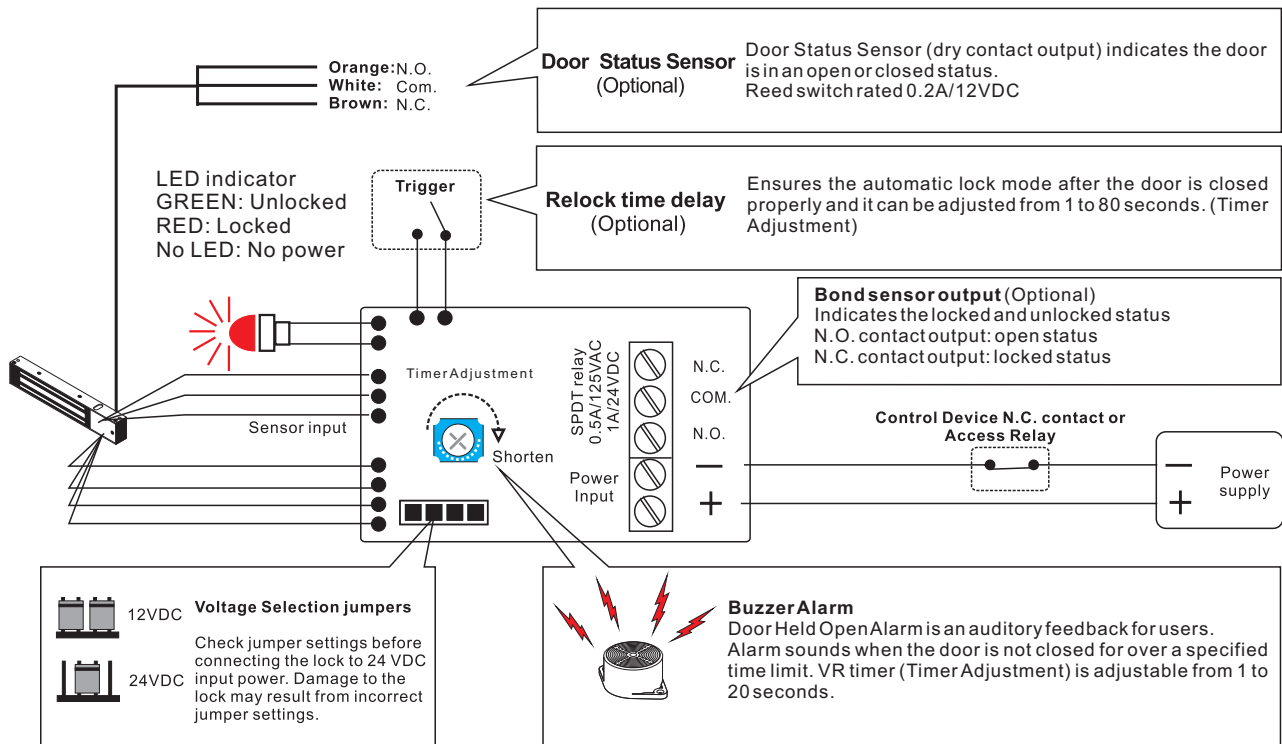

Trouble Shooting

Problem	Possible Cause	Solution
Door does not lock	No power	Make sure the wires are connected properly Check that the power supply is connected and works properly Make sure the lock switch is wired correctly
Low holding force	Poor contact between electromagnetic and armature plate	Make sure if the armature plate is deformed Make sure if the rubber washer was used between the bracket and armature plate Make sure the contact surfaces of the electromagnet and armature plate are clean and free from dust and foreign material
	Low voltage or incorrect voltage setting	Check the electromagnet lock is set for the correct voltage. Check the voltage at the electromagnetic locks input. if low, determine if the correct wire gauge is being used to prevent excessive voltage drop.
Sensor output is not functioning	A secondary diode was installed across the electromagnetic lock	Remove any diode installed across the magnet for "spike" suppression. (The magnet is fitted with a metal oxide varistor to prevent back EMF)
	Misalignment between the armature plate and electromagnetic lock	Make sure the armature plate and electromagnetic lock are aligned correctly